

GOLF EQUIPMENT Under pressure drilling kit

REFERENCE SPECIFICATIONS

Grid	Water
Drilling accessory:	Golf Plus branch tee
	Golf connector



Applications

Golf equipment are used install branch tees and connectors in sizes 1", 1¼", 1½" and 2". They include all necessary elements for ductile iron, asbestos cement, polyethylene and PVC-O pipes.

Equipment box

Equipment box is made of PVC layered board, anodized aluminium edge protection and lock with key. The inside is divided into compartments for correct equipment storage.

Drilling tool

Drilling tool is completely manufactured of hardened steel. The compact design of this drilling tool makes it ideal for use in places with restricted accessibility. It comes with drain valve for emptying shavings produced along the drilling operation.

Operating the drilling tool

Drilling tool is designed to be operated by means of a ratchet wrench, which is supplied with the equipment, or power operated by means of electric, pneumatic or hydraulic motor.

Cutters

Every equipment is supplied with cutters and drill bits for ductile iron, asbestos cement, polyethylene and PVC-O pipes. All cutters incorporate the exclusive Torre octagonal shaft anchoring system. Cutters for PE and PVC-O are special "zero chips" design, collecting all shaving/chips produced by the cutting operation.

Equipment maintenance

Although these equipment do not require any special maintenance, it is advisable to clean and lubricate the drilling tool from time to time. It is also recommended to dry the equipment after each use to avoid limescale deposits, and is also advisable to carry out a check every two years in the factory.

Spare parts

All the components of the Golf equipment can be purchased separately as spares.

GOLF EQUIPMENT Under pressure drilling kit

Technical data

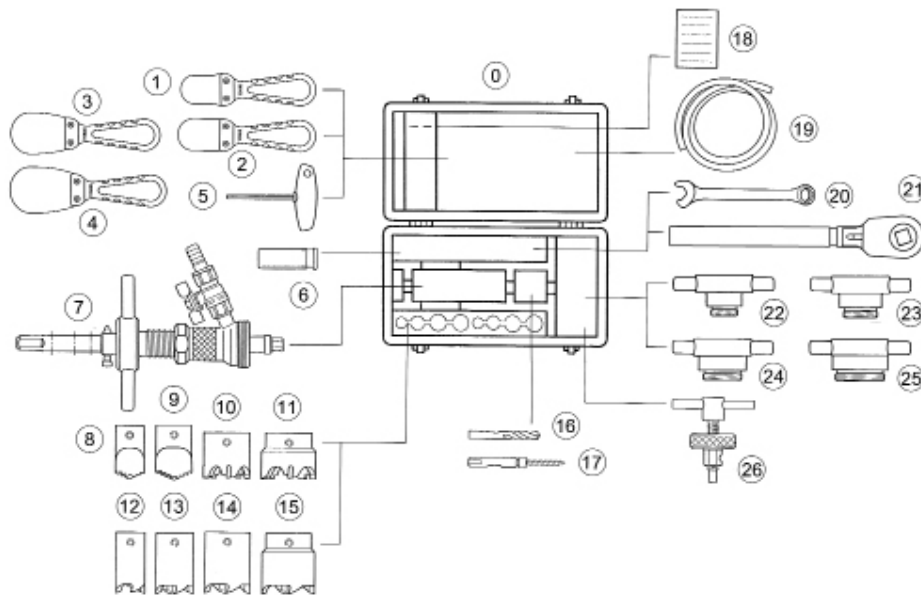

GOLF EQUIPMENT COMPONENTS - 2114 C 03

Nº, NAME, REFERENCES AND UNITS

Nº	NAME	REFERENCE	UTS.	Nº	NAME	REFERENCE	UTS.
0	Golf tool box	2110 C 02	1	12	PE/PVC 1" Cutter	2385 PEC 23	1
1	1" Spatula	1256	1	13	PE/PVC 1¼" Cutter	2385 PEC 29	1
2	1½" Spatula	1257	1	14	PE/PVC 1½" Cutter	2385 PEC 37	1
3	1½" Spatula	1258	1	15	PE/PVC 2" Cutter	2385 PEC 43	1
4	2" Spatula	1259	1	16	Centering drill 6,3 mm diam.	2385 B 6	2
5	3 mm T-handle hex key	1657	1	17	Retaining screw for PVC	2385 T 4	2
6	Spare parts box:		1	18	Check list	--	1
	- Pin with elastic ring	1093	1	19	Drainage hose (2 meters)	8721	1
	- Elastic ring for pin	1108	2	20	19 Combination grip wrench	1940	1
	- O-ring (21 x 3)	JT21X3	2	21	17 mm Ratchet wrench	2481 D	1
	- Stainless steel stud bolts	--	12	22	1" Coupling	1936	1
7	Drilling tool 4 positions	1961	1	23	1¼" Coupling	1937	1
8	1" Integral drill	2385 B 24	1	24	1½" Coupling	1938	1
9	1¼" Integral drill	2385 B 30	1	25	2" Coupling	1939	1
10	FDW 1½" Cutter	2385 FDW 38	1	26	15 Core extractor PE/PVC	1042	1
11	FDW 2" Cutter	2385 FDW 44	1				

EQUIPMENT WEIGHT: 11,5 Kg

